

Revision Notes.

Checked By: Approved By: Date Released:

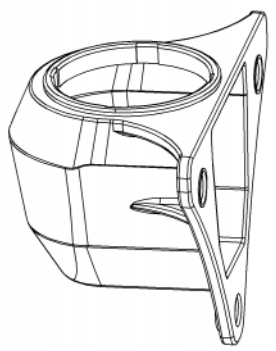

DRILLING TEMPLATE

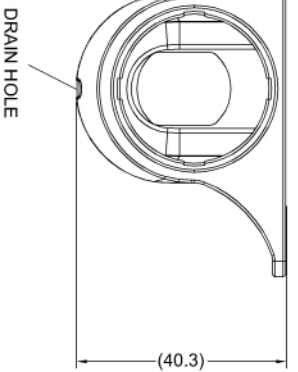
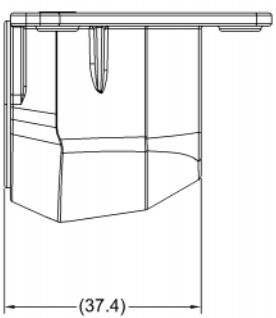
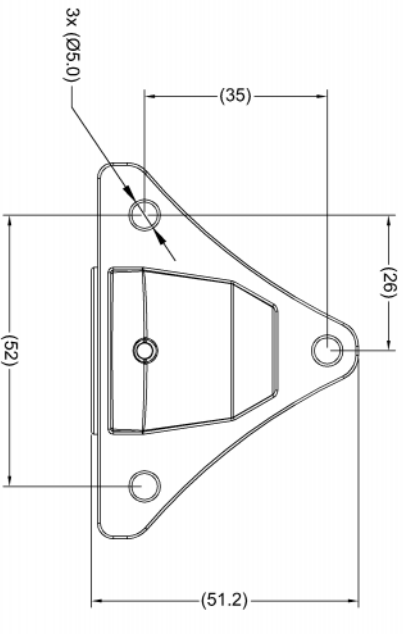
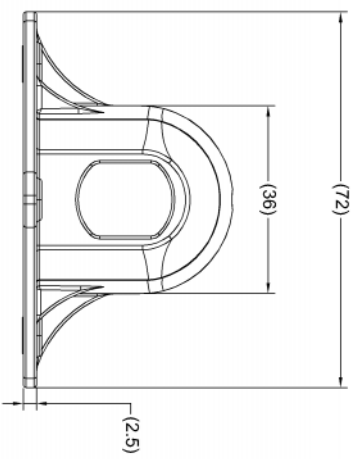
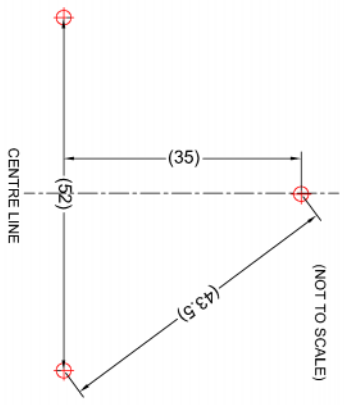

- NOTES:
1. DIMENSIONS IN MM.
  2. MATERIAL: PC PLASTIC +30% ABS.
  3. COLOUR: BLACK
  4. DEFAULT TOLERANCE IS 0.2MM

PROPRIETARY NOTICE  
 THIS DESIGN AND TECHNICAL INFORMATION APPEARING ON THIS DRAWING IS THE PROPERTY OF BRIGADE ELECTRONICS, AND IS DISCLOSED IN CONFIDENCE. IT IS NOT TO BE COPIED, REPRODUCED, REVEALED TO OR APPROPRIATED BY OTHERS, EITHER IN WHOLE OR IN PART WITHOUT THE EXPRESS WRITTEN CONSENT OF BRIGADE ELECTRONICS.

**BRIGADE**  
 www.brigade-electronics.com

Assembly PI Approval LEE DG - 20/07/2011		Approved by SMATTHEWS		Checked by JNEWMAN		Drawn by MPOTTER	
Angle of Projection		Units mm		Scale N/A		Released 01/08/2011	
Third Angle		Status RELEASED		Assembly Ref PP2-0004.7-00		UDS-00SM	
		Stock Code #3726		BE-001635-00-11			